



Magic Concepts[®]
AMAZING MEDIA

Celebrating 30 Years of Sustainability !

Our Cubes are proudly made with PCR Recycled Plastic blocks



For more than 30 years, Magic Concepts® has been committed to producing products responsibly and respectfully, following international social and environmental standards. With millions of items produced, Magic Concepts® understands the importance of taking care of its impact on the environment.

This is why all our blocks are made from post-consumer recycled HIPS plastic.



A Revolution in Sustainable Promotional Products

NEW Magic[★]Bio
CUBE



The 1st Magic Cube injected in plastic-free Biopolymer

3D MEDIA COMMUNICATING INTUITIVELY



01 MULTI-SENSORY BOOST

Every time users play with our 3D Media, it increases their brain neural activity by up to 1000% and boosts your message perception and retention.



02 PLAYFULLY GRASPING THE MEANING

The desire to play with our items generates positive emotions, openness and the willingness to get involved with your Brand. Users understand your message more quickly and remember it more positively.



03 GENERATING DESIRE

Physical interaction with an object increases appreciation and creates a desire for possession. With our 3D Media, users make your message their own. (Scientifically known as "endowment effect")



04 THE MULTIPLIER EFFECT

People like to show our amazing cubes to their colleagues and friends. They like to circulate it and talk about it, indirectly broadcasting your brand and messages through a personal recommendation.



05 LASTING IMPACT

Magic Concepts items boast an exceptionally high retention period in the field of view of their owners, who like to hold them and play with them time and again. Our studies show that this period can last more than 12 months.

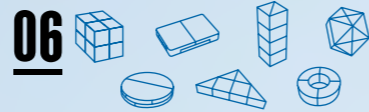

06 UNLIMITED DESIGN OPTIONS

Our range offers plenty of design options. The model can be selected based on your product shape, pictures or the way you want to tell your story.



Our products are protected by Copyrights, Design Registrations & Patents



PRODUCT LAUNCH



ONBOARDING



PORTFOLIO



ANNIVERSARY

ENDLESS APPLICATIONS

Used by most of the FORTUNE 1000 companies



EVENT GIVEAWAY



TRAINING



INTERNAL COMMUNICATION



CORPORATE VALUES

BOOST YOUR CAMPAIGN EFFECT

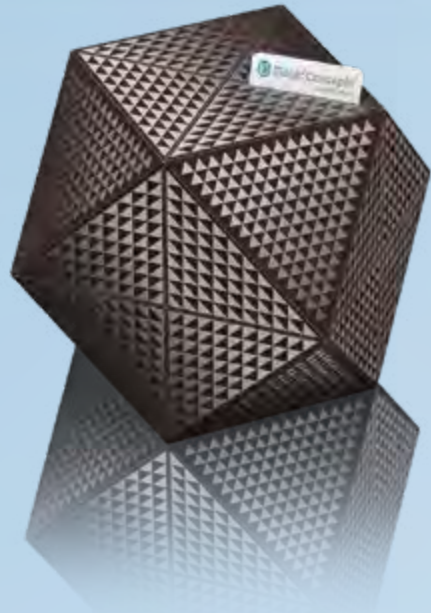

Manifold options are available to increase the impact of your message

SPECIAL PRINTING

We can offer several combinations of Matt/Shiny finishes, spot UV highlights or even Metallic effects.

Our experienced designers will help you with the concept and design of your Magic Concepts® message. Take advantage of the expertise they have gained through thousands of projects to make the most of your campaign.

Contact us to know more or receive samples

AUGMENTED REALITY

This Option, available on most our models, uses people's mobile phone to generate Magical Branded Experiences.

Adding WebAR to your campaign increase user engagement and recall especially with Millennials who are able to share their experience and thus your brand through social media channels.

More on page 20-23



4 COLOR PRINTED BOX



MAILING BOX

SPECIAL PACKAGING

Several packaging solutions are available to perfectly present your Magic Concepts® product, ranging from fully branded box printed inside and outside to our Magic Cube® stand that turns it into a desk sculpture.

Features

- 4C printing
- 1 or 2 side printing
- Matt or Glossy Finish

ALWAYS ASK FOR THE BEST !

Precision labelling

Skilled workers ensure that each label is positioned accurately and precisely, adding to the high-quality finish of each product.

Vegetable ink

Printed with vegetal rather than petroleum-based ink, reducing the release of harmful chemicals into the environment.

Magic+ label

All our Cubes are delivered with Tear-proof and High-Color fidelity labels, ensuring a quality result of your order.



Recycled plastic

Our plastic blocks are manufactured from post-consumer recycled plastic material.

Magic Cube stand

Transforms your Magic Cube® into a hallmark on your desk, increasing its perception-value and its durability.



FOLD & UNFOLD ENDLESSLY !



Magic CUBE

Symbol of Perfection and Creativity, the Magic Cube® works for all brands and messages. When folded, images coincide with images and text in a seemingly endless procession. Whether for a product launch, internal communication, rebranding or calendar, the magic of the cube captivates one and all, and boost your message perception and retention.

5 Sizes available: 50, 60, 70, 80 and 126mm

Recycled plastic

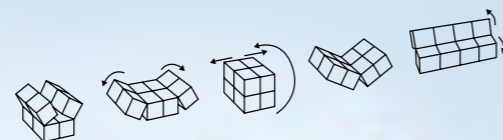

Magic DIAMOND

At first glance, the Magic Diamond appears to be like the Magic Cube®. It's only when touched that it reveals its surprising characteristics and communicative brilliance. With up to 20 panels, the Magic Diamond is the perfect choice to communicate multiple messages such as Company values, Product or Brand portfolio...

2 sizes available: 50 and 70mm

Recycled plastic

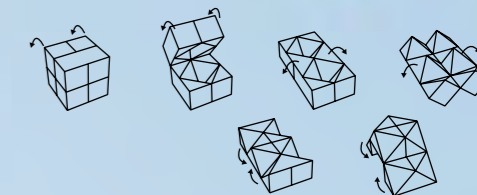

Magic TILE

Thinner than the Magic Cube®, with large panoramic panels revealed one-by-one by an endless movement, the Magic Tile is a perfect mailing solution or 3D brochure that people can put in their bags during a fair or an event.

Size: Closed 83 x 83 x 41mm - Open: 83 x 166 x 41mm

Recycled plastic

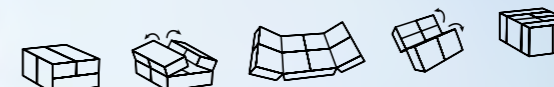

Magic^x X CUBE

NEW

The first "Fidget" Cube with 8 panels for your communication!
A fun item that you can "flip" endlessly, revealing new panels. Ideal for low or high volume campaigns.

Size: 50 x 50 x 50mm

Recycled plastic

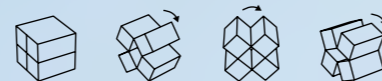

Magic^x ORBIT

Its round shape translates the feeling of completion, wholeness and harmony, but it also hides multiple panels for your communication. Often used for Training or Internal communication the Magic Orbit is also a perfect 3D media if your Logo, Products or Packs are round.

2 sizes: ø103 x 28.7mm, ø76 x 26mm

Recycled plastic



Magic^x ELLIPSE

Another Transformer 3D Media using the same trick as the Magic Can in terms of movement and panoramic views. Designed with a more elegant but less specific shapes, the Magic Ellipse is easier to adapt to different industries. Its ergonomic generates positive emotion that delight people every time they take it in their hand.

Size : 42 x 70 x 115mm (Wide Panel up to 230 x 70mm)

Recycled plastic

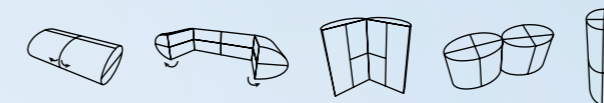

Magic^x CAN

Aside from its look, making it a perfect choice for beverage, or similar shapes products, the Magic Can creates the surprise with its movement. It feels like a Transformer turning into a Can into multiples panoramic views. This unique ability makes it the right option, if you want to communicate emotionally with wide pictures or structure your Training or Internal communication messages.

2 Sizes are available: ø50 x 90mm (wide panel up to : 180 x 50mm)
ø65 x 115mm (wide panel up to : 230 x 65mm)



Recycled plastic

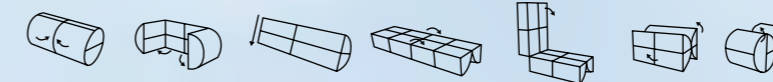

Magic[★] 3 PANEL PEN POT

An Amazing Cube Pen pot that, when unfolded, turns into a panoramic billboard right on people's desk.
The large panels give you the flexibility to communicate emotionally with wide pictures or to structure your training, onboarding or internal communication messages.
Each position is secured by Magnets, to improve its handling and increase the magic.

Closed Size: 70 x 70 x 70mm - Open size : 210 x 70 x 30mm

♻️ Recycled plastic

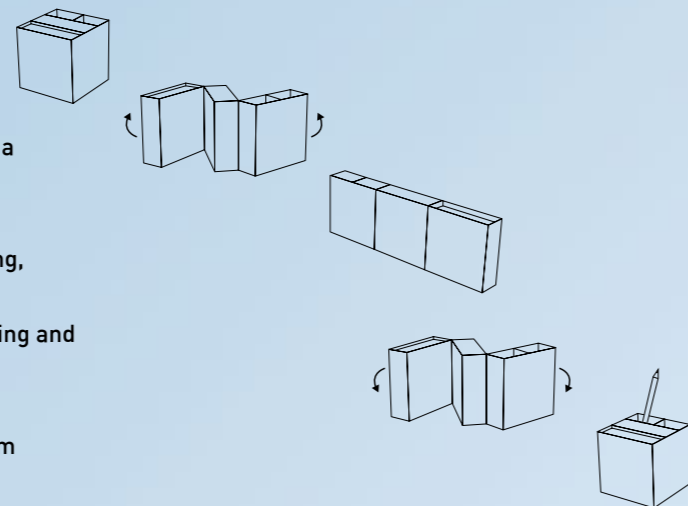

Magic[★] FLIP PEN POT

NEW

A surprising cube-shaped pen pot that, when unfolded, transforms into a panoramic billboard and then into a cube again! It includes 8 large square panels giving you the ability to communicate emotionally with visuals or text, to structure your training, onboarding or internal communication messages.
Each position is secured by magnets, to improve its handling and increase the magic.

Closed Size: 70 x 70 x 70mm - Open size : 140 x 70 x 35mm

♻️ Recycled plastic

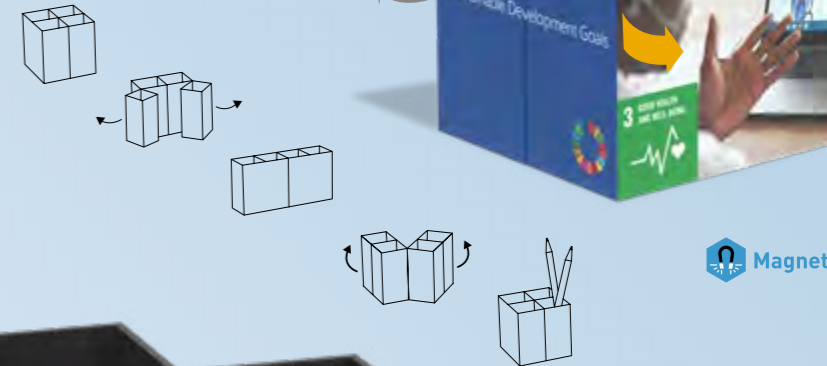



Magic^x MAILING BOOSTER CARD 160

An ideal mailshot or 3D sales aid that fits in a regular envelope or in your pocket. The Credit card shape associates a feeling of high-value to your communication, but the real magic comes from its endless movement.

Size: 160 x 100 x 2mm

Recycled plastic

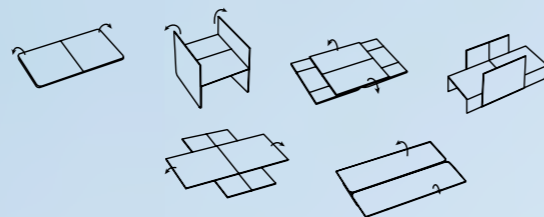

Magic^x CARD 210

A long-lasting Mailing solution with all the Magic Concepts[®] DNA. The Magic 210 is the mailer people will keep. Its large Panoramic panels increase the impact of your communication, and its movement gamifies your messages, making them more positive and easier to remember.

Size: 210 x 95 x 2mm

Recycled plastic



Magic^x CARD 150

A playful and long-lasting Magazine inserts or Brochure. The square shape conveys the feeling of balance and perfection, while its endless movement creates the real magic that increases the perception and retention of your messages.

Size: 150 x 150 x 2mm

Recycled plastic



Visit www.mcamazingmedia.com for other Magic Folding shapes:

Magic^x RING



Magic^x TRIANGLE



Magic^x CONTAINER



Magic^x FLIP



Magic^x HOUSE XL



THE MAGIC OF MAGNETIC !



Magic^x MAGNETIC TRIANGLE

Composed of 4 Magnetically connected prisms, this amazing puzzle invite you to play and create sculptures. It's fun and addictive! Its 20 panels allow you to communicate multiple messages such as company values, key selling points, achievement... or design it as a perfect Calendar.

Size: 70 x 70 x 49mm

Recycled plastic



Magic^x 360 ROUND

Designed as a desk tower billboard, magically connected with magnets, the Magic 360 line is the object your employees or clients will keep touching and playing all day long, during their phone call or to relax their mind. An effective 3D Media for Internal communication, Training, Onboarding or Company's values.

Size: 60 x 60 x 135mm

Recycled plastic



Magic^x 360 SQUARE

Another tower billboard sharing the same DNA as the Magic 360 Round. Made of 3 Magnetic cubes this widget will display your messages on your employee and client's desk and boost their perception and retention.

Size: 50 x 50 x 150mm

Recycled plastic



TWIST AND ROTATE PLAYFULLY!

Magic[×] STATIONERY BOX

A playful stationery box offering 4 large square panels of 70x70mm each, easy to personalize with your pictures and messages. The 3 sliding compartments gamify your messages, making them more positive and easier to remember.

Size: 70 x 70 x 70mm



Magic[×] REVOLVING TOWER

The Magic Revolving Tower is an invitation to play and relax your hands and mind. But that's not all, once on your desk, you cannot resist the pleasure to move the blocks and discover the different messages those 4 cubes have to offer. An effective 3D Media if you want your employees and clients not only to read your message but also remember it positively.

Size : 69 x 69 x 260mm



Magic[×] SLIDING HIGHLIGHTER

The Magic Sliding Highlighter Set is composed of 3 markers that double as a clever puzzle, thanks to their sliding and magnetic system. When users finish highlighting, they cannot resist the pleasure of playing and recomposing your logo/message, hence memorizing it.

Size: 20 x 20 x 63mm



Magic[×] SUSPENSION

An interactive 3D Media designed to gamify your messages. Once on your desk, you cannot resist the pleasure to rotate the blocks, mix and recompose your logo/message again-and-again. A physical interaction that increases users perception, making your brand and messages their own.

Size : 53 x 60 x 160mm

ADD MAGIC WITH OUR WebAR OPTION



WHAT IS WebAR?

WebAR is an AUGMENTED REALITY Option available for most of our 3D Media, using your mobile phone to generate Engaging Branded Experiences

HOW IT WORKS?

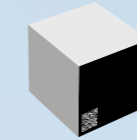

Scan QR Code
on the cube



Frame the face with
the AR Logo and
enjoy the experience

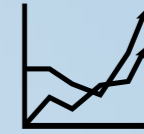

Track campaign
results via our
platform



3D logo



Video

WHY ADD WebAR TO YOUR 3D MEDIA?

Adding WebAR to your campaign increases user engagement and recall, especially with Millennials who are able to share their experience and thus your Brand through social media channels.



ENGAGEMENT :

From AR Magic to Logo gamification



MEDIA VALUE :

Video adds Media Value to the Product



PROOF OF EFFECTIVENESS :

Tracking turns blind communication into Proven Marketing Results



SOCIAL SHARING :

Social Media Sharing gives Visibility to your Brand

**With WebAR, users scan a QR code on your Cube,
and immediately start the experience in their phone's browser.
No need to download an App!**



Magic[✶] WebAR 3D LOGO

An option adding magic to your campaign, with a virtual logo the user can interact with. An amazing experience that can be shared on Social Media.

- Adds magic to your messages
- Gamifies your Brand
- Gives you extra visibility on Social Media [f](#) [t](#) [@](#)

Magic[✶] WebAR VIDEO

This option provides an additional layer of excitement to the message printed on the cube, with motion, sounds and music. An amazing experience that can be shared on Social Media.

- Allows Brands to deliver a video message, presentation, or advertisement
- Gives you extra visibility on Social Media [f](#) [t](#) [@](#)





www.mcamazingmedia.com

Magic Concepts is an internationally registered brand name.

The Magic Concepts logo/cube icon testifies the authenticity of the product.
Any infringements on our patents or brand rights will be strictly subject to legal action.

UK distributors:



Preseli Ltd

Unit 4 Ashmount Industrial Centre, Castle Park, Flint, Flintshire, CH6 5XA

t: 01352 730006

e: sales@preseli.biz

w: www.preseli.biz